

FOR LEASE

1,000 Sq. Ft. (+/-)

LIZOTTE

AND ASSOCIATES REAL ESTATE INC



10653 Winterburn Road Edmonton, AB

SMALL OFFICE ON 0.25 AC OF LAND IN WINTERBURN

Property Highlights

- 1,000 Sq. Ft. building with 0.25 acres of land
- Sea cans can be placed on site
- Ideal for contractors, landscaping, storage, etc.
- Well-appointed office space with character appearance
- Direct exposure to Winterburn Road
- Fenced and gated yard



780.488.0888



www.lizotterealestate.com



#1200, 10117 Jasper Avenue
Edmonton, AB T5J 1W8



No warranty or representation, expressed or implied, is made as to the accuracy of the information contained herein, and same is submitted subject to errors, omissions, change of price, rental or other conditions, withdrawal without notice, and to any specific listing condition, imposed by our principals.

FOR LEASE

Small Office in Winterburn

LIZOTTE
AND ASSOCIATES REAL ESTATE INC



FOR LEASE

Small Office in Winterburn

LIZOTTE
AND ASSOCIATES REAL ESTATE INC

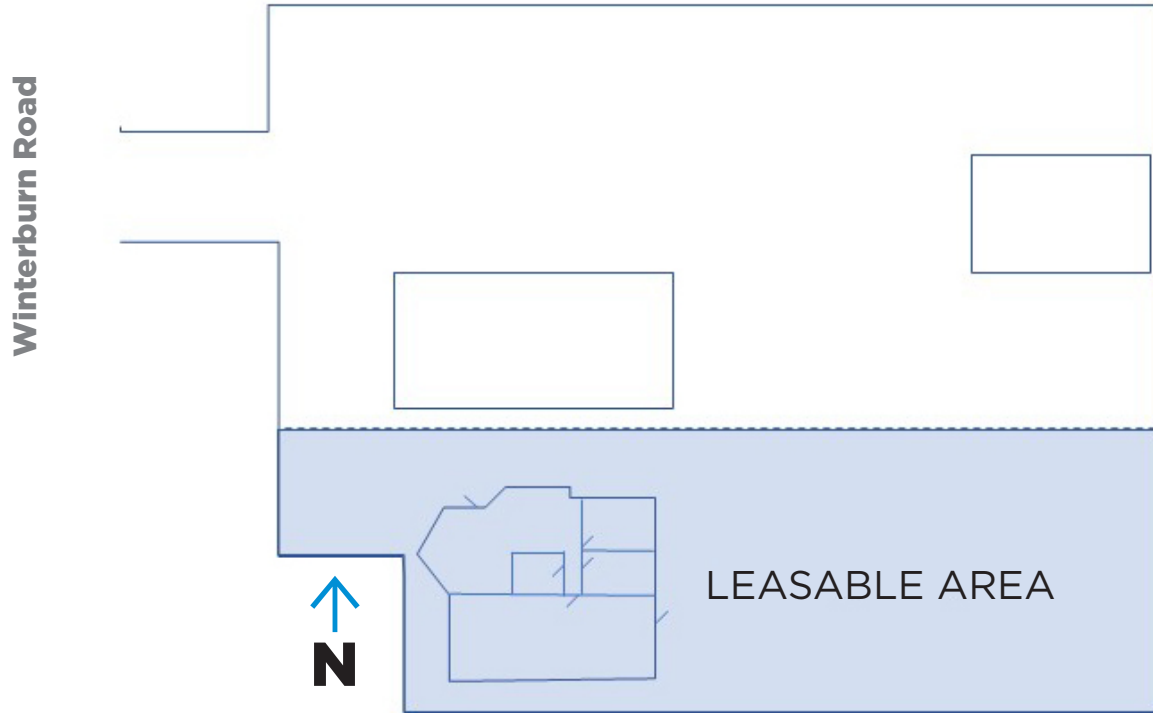

780.488.0888



www.lizotterealestate.com



#1200, 10117 Jasper Avenue
Edmonton, AB T5J 1W8



No warranty or representation, expressed or implied, is made as to the accuracy of the information contained herein, and same is submitted subject to errors, omissions, change of price, rental or other conditions, withdrawal without notice, and to any specific listing condition, imposed by our principals.

FOR LEASE

Small Office in Winterburn

LIZOTTE
AND ASSOCIATES REAL ESTATE INC

Property Information

Municipal Address: 10653 Winterburn Road, Edmonton, AB

Size: 1,000 Sq. Ft. (+/-)

Lot Size: 0.25 Acres

Zoning: IM (Medium Industrial)

Possession: Immediate/negotiable

\$\$\$

Lease Rate: \$3,200/Month + Utilities

Contact

Chuck Clubine

Senior Associate

Cell: 780.264.7773

Direct: 780.784.6553

chuck@lizotterealestate.com

Tom Dean

Associate

Cell: 780.920.8019

Direct: 780.784.6550

tom@lizotterealestate.com

