

FOR LEASE

1,300 Sq. Ft. (+/-)

LIZOTTE

AND ASSOCIATES REAL ESTATE INC

 **HI-TECH**
HOME DESIGNS

 **Natural Massage**
—STUDIO—



6734 - 75 Street, Edmonton, AB

SMALL OFFICE BAY WITH GRADE LOADING

Property Highlights

- High exposure site on 75 Street
- Over 41,000 vehicles pass the site daily
- High end finishes within the bay
- Suitable for office users in the front, and small storage area with grade loading in the back
- Ample on-site parking, and good marshaling area in the back
- On-site management



780.488.0888



www.lizotterealestate.com



#1200, 10117 Jasper Avenue
Edmonton, AB T5J 1W8



No warranty or representation, expressed or implied, is made as to the accuracy of the information contained herein, and same is submitted subject to errors, omissions, change of price, rental or other conditions, withdrawal without notice, and to any specific listing condition, imposed by our principals.

FOR LEASE

Small Office Bay With Grade Loading

LIZOTTE
AND ASSOCIATES REAL ESTATE INC

Floor Plan

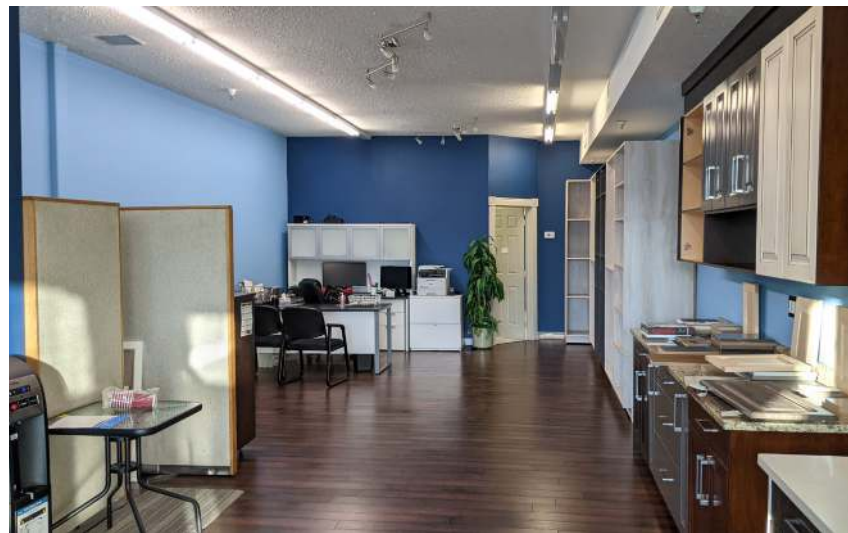
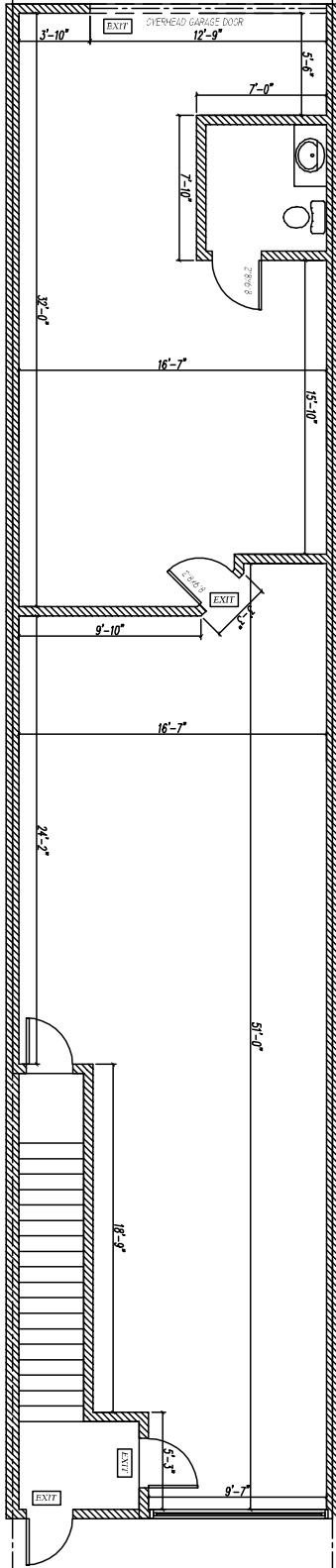

FOR LEASE

Small Office Bay With Grade Loading

LIZOTTE
AND ASSOCIATES REAL ESTATE INC

Property Information

Municipal Address: 6734 - 75 Street, Edmonton, AB

Size: 1,300 Sq. Ft. (+/-)

Zoning: IB (Business Industrial)

Loading: 10'x10' Door At Grade

Parking: Ample Scramble Parking

Possession: Immediate

\$\$\$

Lease Rate: \$14.00/Sq. Ft.

OP Cost: Est. \$10.00/Sq.Ft.

Contact

Chuck Clubine

Senior Associate
Cell: 780.264.7773
Direct: 780.784.6553
chuck@lizotterealestate.com

Tom Dean

Associate
Cell: 780.920.8019
Direct: 780.784.6550
tom@lizotterealestate.com

Harry Yadav

Unlicensed Assistant
Cell: 780.288.5172
Direct: 780.784.5359
harry@lizotterealestate.com

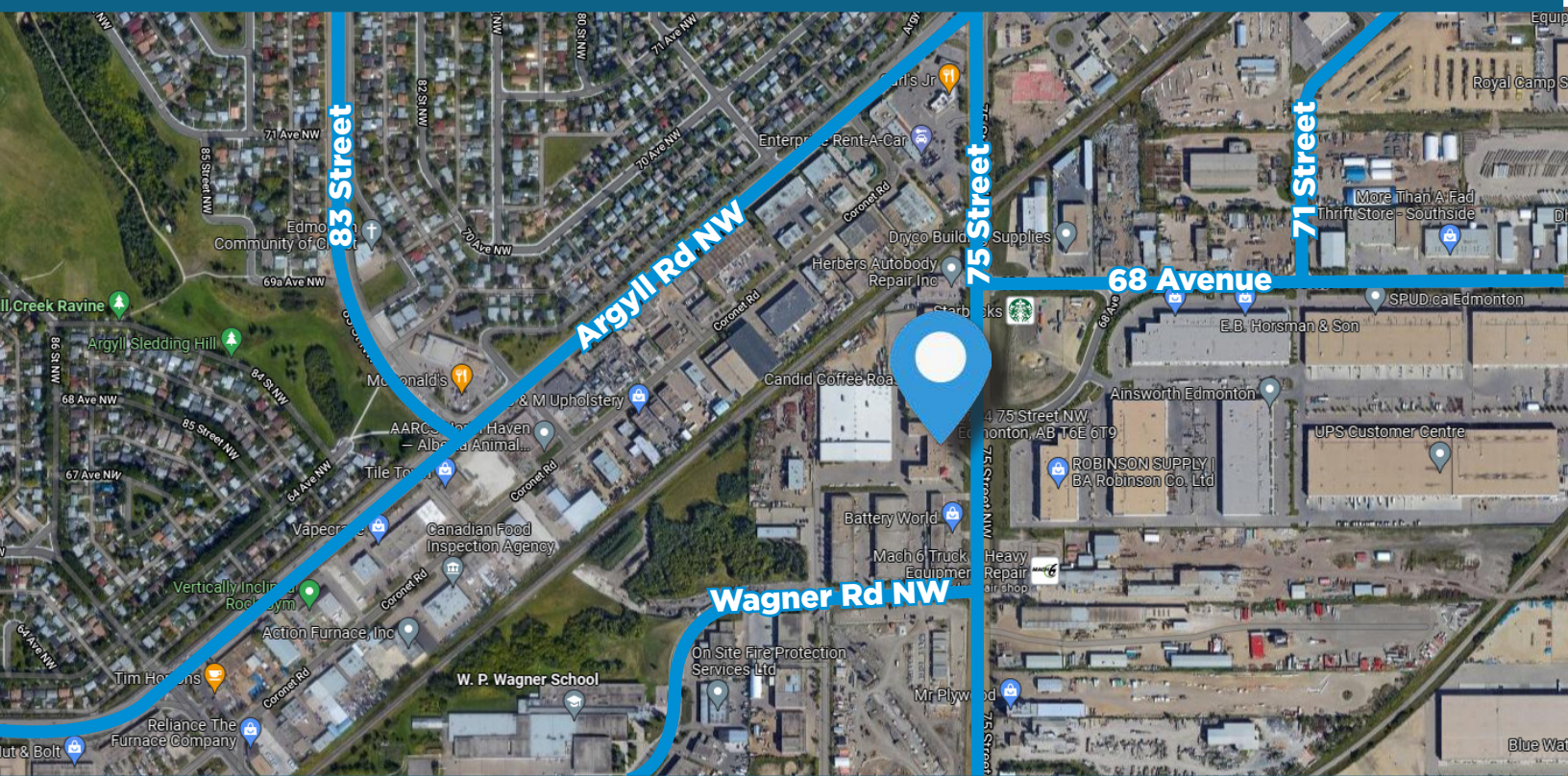

780.488.0888



www.lizotterealestate.com



#1200, 10117 Jasper Avenue
Edmonton, AB T5J 1W8

No warranty or representation, expressed or implied, is made as to the accuracy of the information contained herein, and same is submitted subject to errors, omissions, change of price, rental or other conditions, withdrawal without notice, and to any specific listing condition, imposed by our principals.